

Miller Lifting Products  
 100A Sturbridge Rd.  
 Charlton, MA 01507 USA  
 T: +1.508.248.3941  
 E-mail: sales@millerproducts.net



## OVERHEAD CRANE BLOCKS CUSTOM QUOTE REQUEST

Requestor name	Date	Quantity
Company & address		
Phone and E-mail address		

**SHEAVES**

NUMBER OF SHEAVES: \_\_\_\_\_ PITCH DIAMETER: \_\_\_\_\_ OUTSIDE DIAMETER: \_\_\_\_\_

WIRE ROPE SIZE: \_\_\_\_\_ NUMBER OF LINE PARTS: \_\_\_\_\_ EQUALIZER? \_\_\_\_\_

ROLLER BEARING \_\_\_\_\_ BRONZE BUSHING \_\_\_\_\_

**BLOCK CAPACITY & DIMENSIONS**

DIMENSIONS: A \_\_\_\_\_ B \_\_\_\_\_ C \_\_\_\_\_

WORKING CAPACITY (LOAD LIMIT): \_\_\_\_\_  
 (INDICATE US / METRIC TONS)

DESIGN FACTOR: \_\_\_\_\_

**HOOK TYPE**

SINGLE \_\_\_\_\_ DUPLEX \_\_\_\_\_ LOCKING \_\_\_\_\_

LOCKING HOOK \_\_\_\_\_ INSULATED HOOK \_\_\_\_\_

OTHER \_\_\_\_\_

**OTHER REQUIREMENTS**

CMAA SERVICE CLASS: \_\_\_\_\_

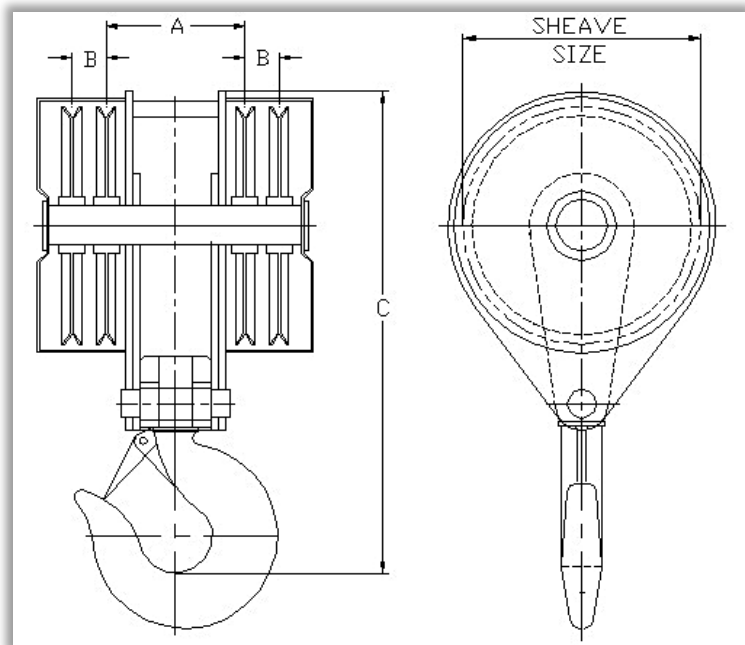

SPECIAL TESTING, THIRD PARTY INSPECTION, OVERHAUL WEIGHT, ETC:

---



---